

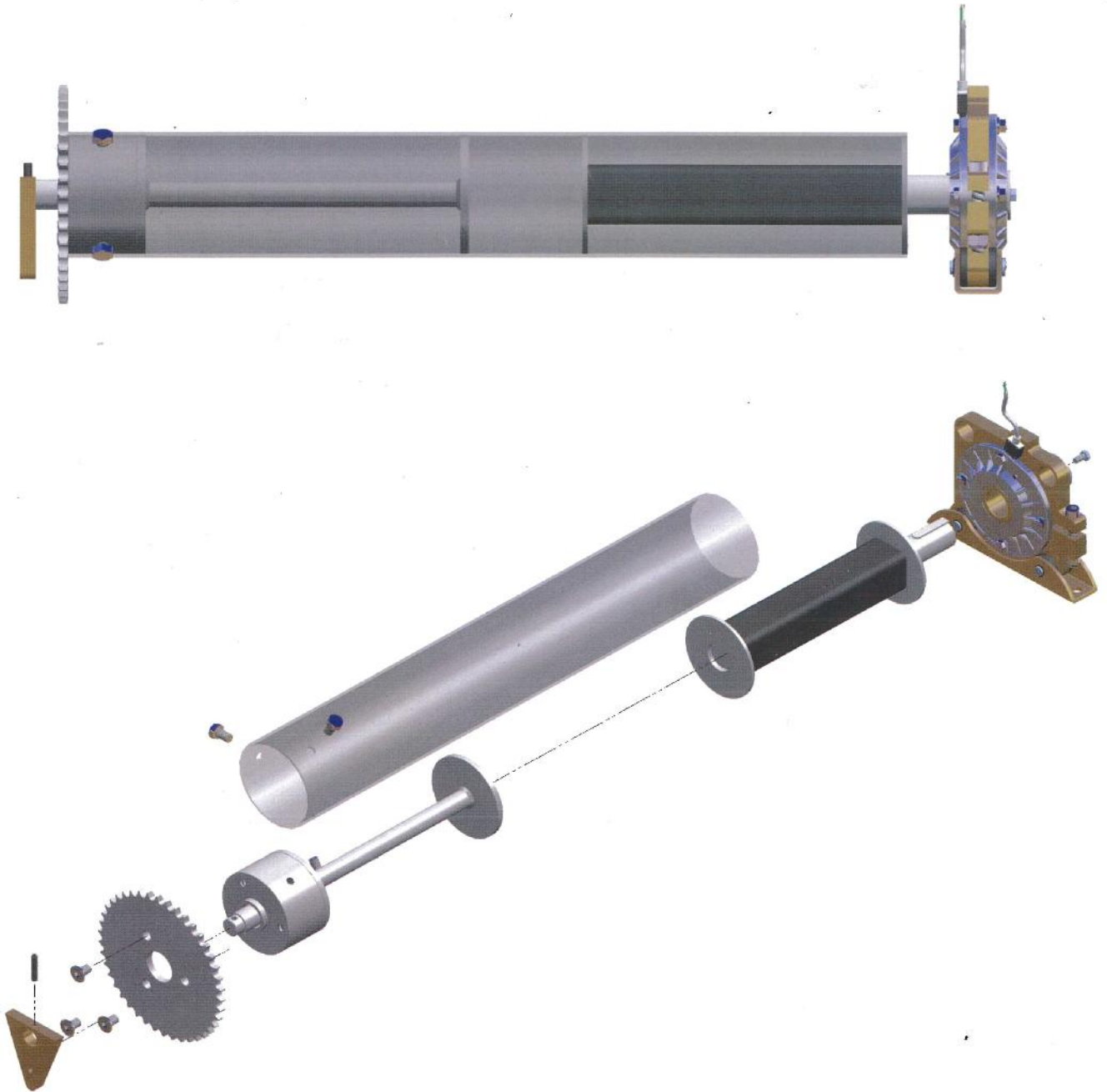

ParaFIX

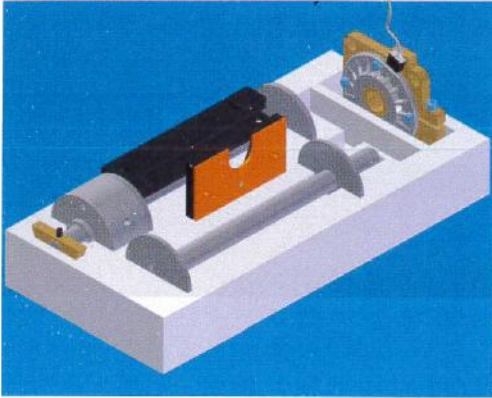



CONTENTS

- 1) Inertia brake
- 2) Complete Drive end with V drop
- 3) Dummy end
- 4) 2 Landing brackets for Inertia Brake (left & right)
- 5) Spanner
- 6) V block
- 7) Clamp plate
- 8) Nuts & Bolts
- 9) Instructions

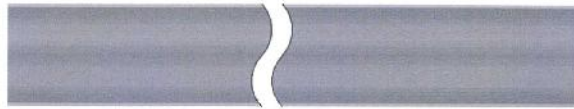

1) Cut barrel to size.



2) Remove V DROP from Drive End.

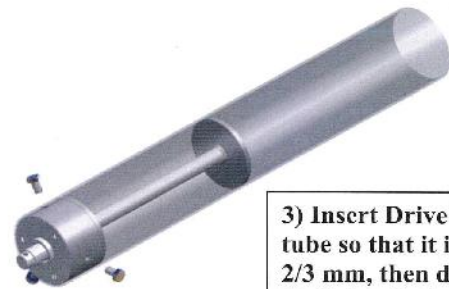

3) Insert Drive End into the tube so that it is protruding 2/3 mm, then drill tube and fix Drive End with bolts provided.



4) Insert Telescopic dummy end into the tube so that is protruding 1-2 mm, then weld.'



5) Fit Sprocket which is packed with motor then re fit V Drop ensuring roll pin is tapped home.

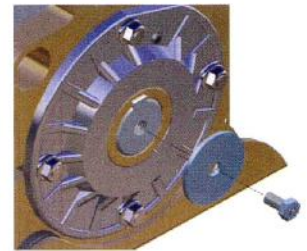
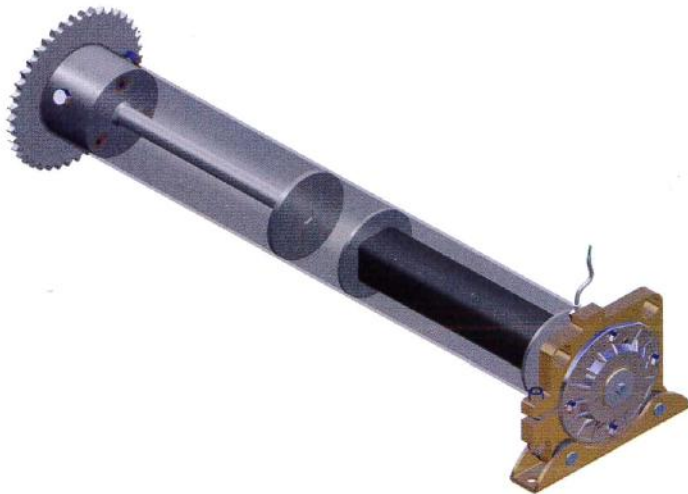

6) Fit Inertia Brake onto dummy end and secure it by using the disc and bolt provided.
IMPORTANT:
Ensure that the arrow on the Inertia Brake points in the closing direction of the door.

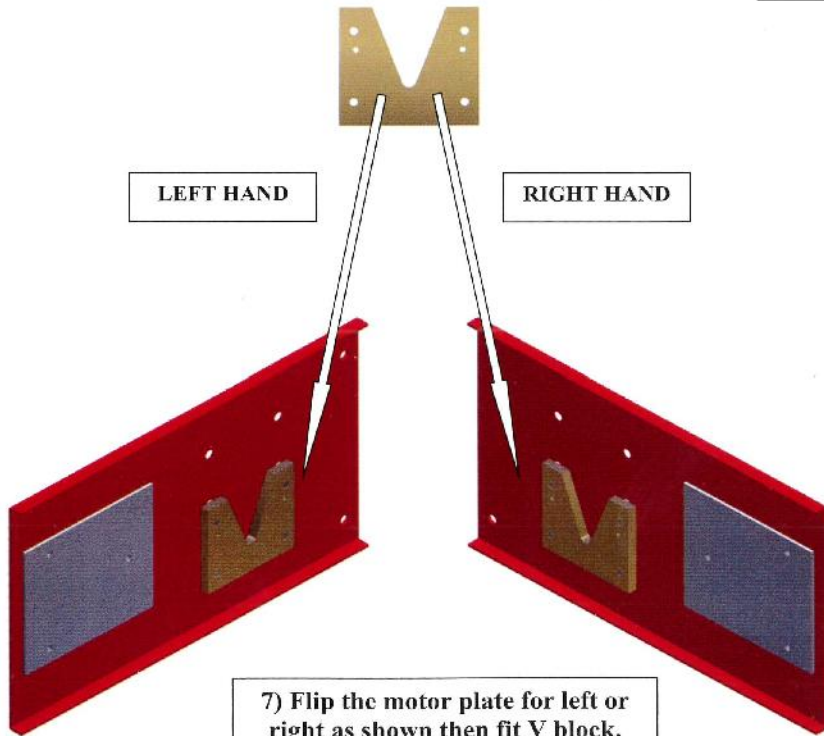

7) Flip the motor plate for left or right as shown then fit V block.



8) After fitting V block onto motor plate fit clamping plate with two bolts only loosely as shown.

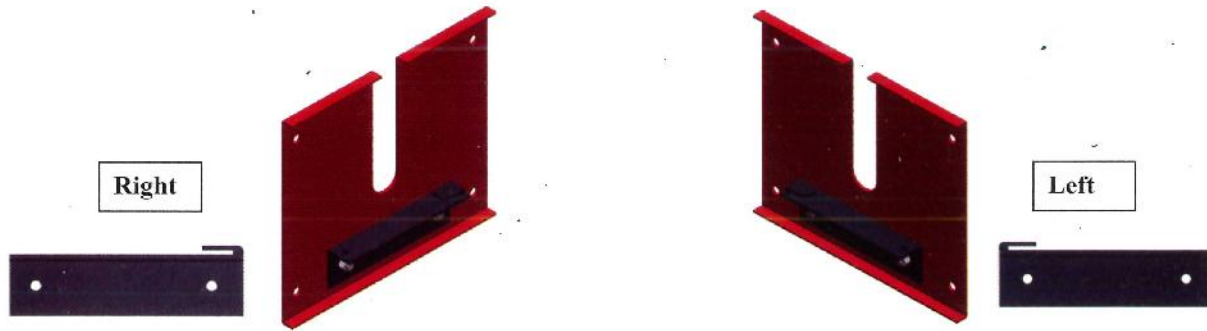

9) Bolt either Left or Right Inertia Brake Landing Bracket depending on the hand of your door.

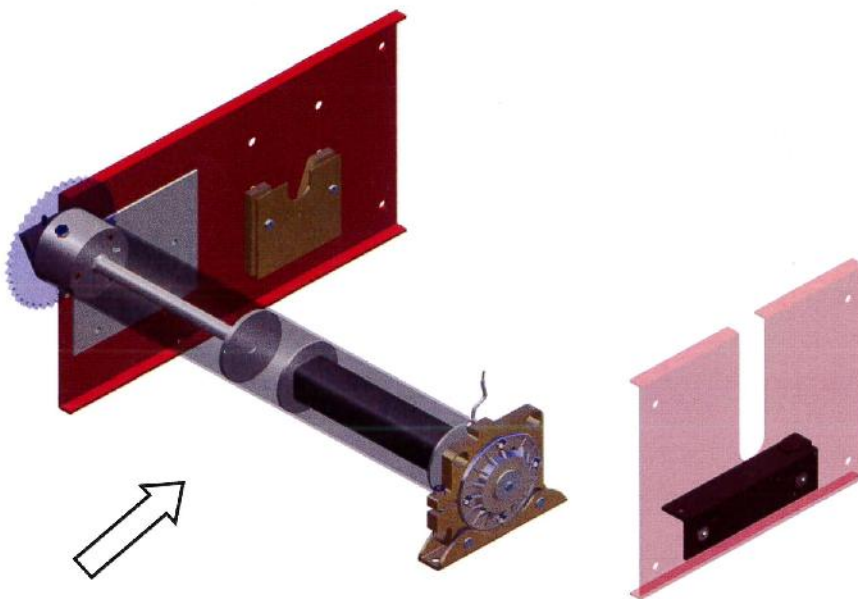

10) Lift the barrel, slide it between the plates and drop into final position.



11) Secure inertia brake with one M12 bolt and nylock.

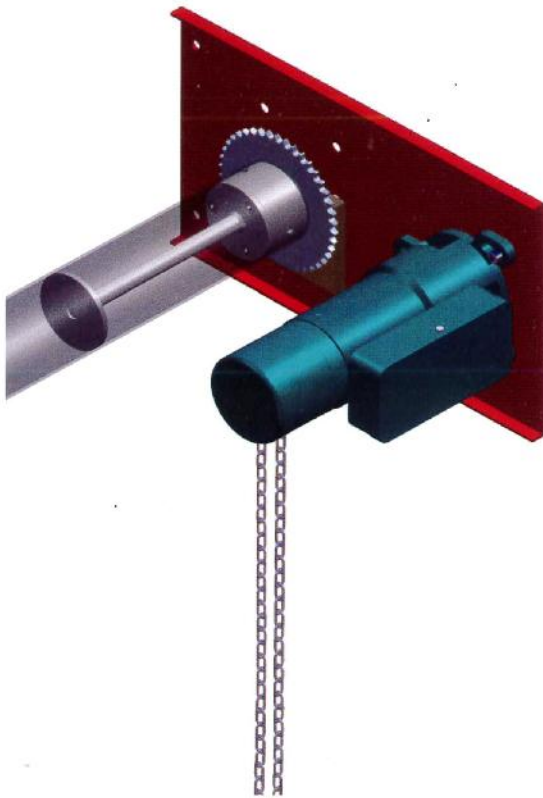

12) Fit motor.

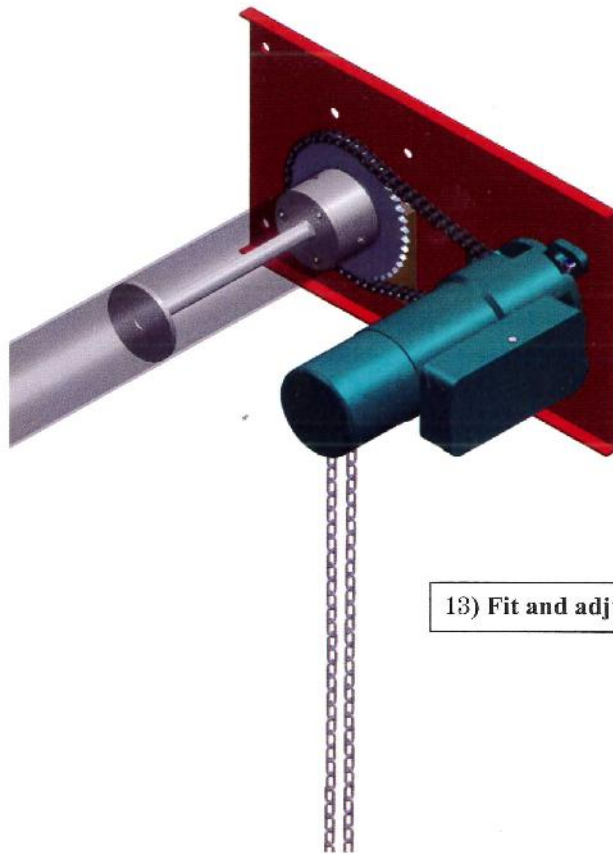

13) Fit and adjust drive chain.

